

# Non-Adjustable Flow Switches



## M-60 Series

Fixed setting flow switch  
with in-line flow

### Features

- For corrosive and non-corrosive liquids or gases
- Senses increasing or decreasing flow
- Very accurate custom flow settings
- Hermetically sealed
- All-Teflon® switch available
- Universal mounting available

### Applications

- Sample flow monitoring
- Alarm actuation
- Purge flows
- Loss of flow protection
- Semiconductor etch tools
- Laser cooling equipment

The M-60 flow switches monitor increasing and decreasing flow. They utilize a single moving part which responds to fluid (liquid or gas) flowing within a system. These switches are suitable for a wide range of applications used in semiconductor, industrial, biomedical, and OEM products. The flow monitors operate only when fluid flow is positively established. The M-60 is available standard with 1/4" FNPT connections.

### Operation

The operating principle is based on a free floating magnetic piston which responds only to the motion of fluids within the line, not to static or system pressures. In the presence of fluid flow, controlled movement of the piston actuates an external hermetically sealed reed switch thus producing the required signal. This signal can be used to actuate audible or visual alarms as well as relays, or other control. Piston travel is short which insures low hysteresis. Pressure drop across flow switch varies from 0.035 to 2 psi (at maximum flow rates for air and for liquid). Universal mounted units are outfitted with a spring which resets the piston. The spring is held in place using an orifice disc.

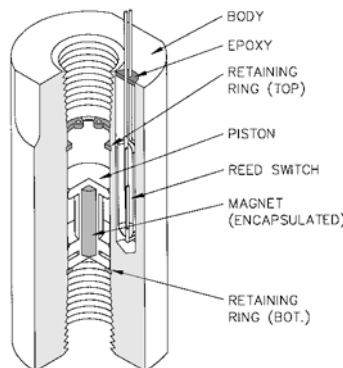

Illustrated is the M-60 Model with 1/4" ports.

### Calibration Range \*

Air: 25,000 - 55,000 scc/min  
Water: 750 - 1,600 cc/min

\* For lower and higher trip points contact factory. Maximum flows through switch are higher.

### Specifications

Set Point Accuracy: ±10% maximum  
Repeatability: ±2%  
Hysteresis: 15%

### Material Versions \*

- Acrylic
- Aluminum (Anodized)
- 316 Stainless Steel
- Teflon®

\* Other materials available on request.

### Port Sizes

- 1/4" FNPT

### Custom Versions Available

Malema welcomes the opportunity to apply its flow sensor experience to work for its customers. Please contact the factory for any special requirements; such as ports, extreme temperature and pressure capabilities, etc.

## Design Considerations/Construction

The M-60 Series comprises a Body, Piston, and Retaining Rings. Selecting a Flow Switch begins with selecting the body; this series is available in a number of materials. The M-60 Series contains one moving part (i.e. the piston) and two retaining rings that are in the fluid path. Construction of the piston is important from a design perspective. We manufacture three types of pistons (it is critical to select the correct piston for your application): 316 Stainless Steel, Teflon Encapsulated, and Special All-Metal piston.

(1) The standard piston is a 316 Stainless Steel piston with **epoxy** to hold the magnet in place. This piston is recommended for non-aggressive fluids and inert gases. Stainless Steel retaining rings are typically used with this piston type.

(2) The second piston that is available is a Teflon Encapsulated one. This piston is a magnet that has Teflon molded around it and then machined to the appropriate configuration. These pistons are primarily used in Teflon flow switches and also in other flow switch bodies (typically 316SS and Acrylic bodies) where customers prefer a piston that does not have epoxy in the fluid path; as well as a piston that is impervious to aggressive fluids and gases. This piston is highly recommended for medical applications. Hysteresis on these pistons does tend to be slightly higher (10 to 15%) than metal pistons due to frictional effects, weight, and surface adhesion considerations. Prior to selecting this piston, fluid temperatures and fluid compatibility with Teflon must be taken into account because certain aggressive chemicals at specific temperatures tend to swell Teflon causing the piston to change shape resulting in failure of the product. Stainless or Teflon retaining rings can be used with this piston.

(3) The third piston that is available is a Special All-Metal piston with **no epoxy** (only available in 316SS). This piston is fabricated in a proprietary process with only one weld seam (leak tested) which presents an all 316SS surface to the fluid path. This piston is recommended for those applications where the piston could experience a lot of cycling wear. This piston has been tested to 250,000 cycles at 125 psi. Stainless Steel retaining rings are recommended for this piston type.

## Standard Specifications by Materials

Housing	Acrylic	Aluminum		316SS	Teflon (PTFE)	
Piston*	316SS	316SS		316SS	Teflon	
Orifice Plate or Disc	Stainless Steel				Teflon	
Spring	Stainless Steel				N/A	
Retaining Rings*	Stainless Steel (PH 15-7 MO, AMS 5520, AISI-632) (Passivated)				Teflon	
<b>Pressure &amp; Temperature</b>						
Maximum Operating (psig)	200	1,000		3,000	80	
Burst (psig)	400	2,000		5,000	160	
Maximum Operating Temperature	77 C (170°F)	149 C (300°F)		149 C (300°F)	104 C (220°F)	
<b>Reed Switch Data</b> (Electrical Ratings) Reed Switch	10 Watts SPST or 3 Watts SPDT (Hermetically Sealed) UL Recognized. File E47258. Operating Temperature -40°C to 125°C					
Switching Voltage	200 VDC (170 VDC for SPDT)					
Breakdown Voltage	250 VDC (200 VDC for SPDT)					
DC Resistive	10 Watts (3 Watts for SPDT)					
AC Resistive	10 VA (3VA for SPDT)					
Switching Current	0.5 A (0.25 A for SPDT)					
Carrying Current	1.2 A (0.5A for SPDT)					
Lead Wires	No 24 to 18 AWG. 18" Length, Polymeric UL Recognized (Belden cable or special shielded cable is available)					
Lead Wires Color	SPST: 2 Blue wires; SPDT: Green - Common, Yellow - Normally Closed, Orange - Normally Open					
Flow Calibration	(Higher accuracy units available)					
Set Point Accuracy	10% maximum					
Set Point Differential (Deadband)	15%					
Repeatability	± 2% maximum					

\* See "Design Considerations/Construction" above

## Reed Switch Ratings as Recognized by UL

SPST	120 V ac 24 V dc 50V dc	0.1 A general purpose 0.25 A resistive 0.25 A resistive
SPDT	120 V ac 10 V dc 24 V dc	0.1 A general purpose 0.25 A resistive 0.1 A resistive

# Non-Adjustable Flow Switches

## Installation & Maintenance

The standard switch has to be mounted vertically in the position shown above for normally open conditions and inverted position for normally closed conditions. When inverted, the switch set-point will change by  $\pm 5\%$ ; please use the product in the orientation it was calibrated (as indicated by reading the label). Universal units can be mounted horizontally or vertically. Please advise mounting orientation while ordering, so that the factory can calibrate in the required orientation as calibration does change when changing orientation. Adequate filtration and sealing procedures should be used when mounting in flow lines. For detailed directions, please refer to our "Installation and Maintenance" sheet.

## Certifications

- UL and Canadian UL Recognized for ordinary locations. File E138467
- Meet the intent of Directive 89/336/EEC for Electromagnetic Compatibility and Low Voltage Directive 73/23/EEC for Product Safety. Compliance was demonstrated to the following specifications as listed in the Official Journal of the European Communities: EMC Directive 89/336/EEC: EN 55011, Class B Radiated Emissions, EN 50082-1 (Immunity); IEC 801-2, Electrostatic Discharge Immunity, IEC 801-3, RF Electromagnetic Field Immunity; Low Voltage Directive 73/23/EEC: EN 61010-1, Safety Requirements for electrical equipment for measurement, control, and laboratory use.

## Cv at typical set points

M-60	Water cc/m	Air scc/m	Cv
	850	30,000	0.43
	1595	55,000	0.54

## Dimensional and Cut-Away Drawings

*Illustrated is the M-60 Model with 1/4" ports.*

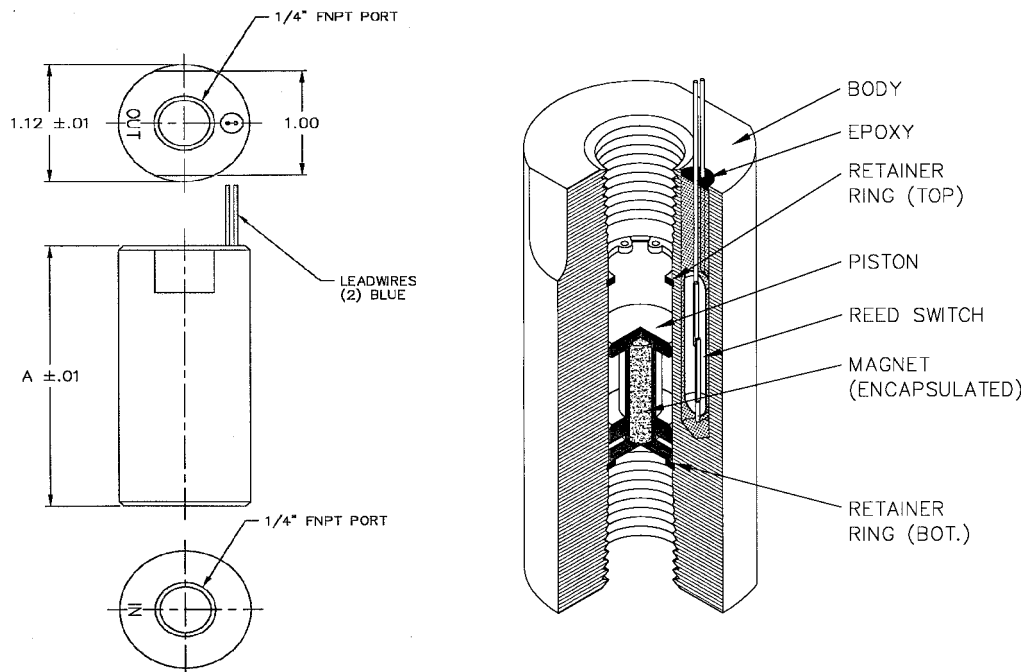

Material	"A"
Acrylic	2"
Aluminum	2"
Brass	2"
316SS	2.5"
Teflon	2.25"

## Fixed Flow Setting Information

This model is a FIXED flow switch. The flow set point is fixed at the factory and is NOT field adjustable. Proper calibration of the set point requires the following information. When purchasing a flow switch, use the "Set Point Calibration" form on page i-vi or provide this information on the purchase order.

- Calibration set point,
- Increasing or decreasing flow,
- Fluid type (i.e. liquid or gas),
- Density or specific gravity,
- Viscosity,
- System pressure and temperature,
- Flow direction (i.e. upward or downward), and
- Mounting orientation (i.e. horizontal or vertical).

## Ordering Information

Standard Part Numbering						Options			
M	-	Model	-	Material	Port	Switch	-	Mounting	Piston
M	-	60	-	S	2	1	-	0	0
		60		A - Aluminum P - Acrylic S - 316 Stainless T - Teflon®	2 - 1/4"	1 - SPST N.O. 2 - SPST N.C. 3 - SPDT 4 - DS (Two SPST)		0 - Standard (Vertical) 1 - Universal Mounting (with disc and spring)	0 - Standard* (316SS with epoxy) 1 - Teflon® encapsulated 2 - All-316 SS(no epoxy)

\* The standard piston on the Teflon version is Teflon encapsulated.

Teflon® is a registered trademark of DuPont.